

THREE-PHASE MOTOR: From 2.7 up to 13 CV (2 / 9.5 kW)

230 V-400 V-415 V ; (50/60 HZ)

MONO-PHASE MOTOR: From 2 up to 8 CV (1.5 / 6 kW)

PUMP: From 30 up to 150 L/min.

PRESSURE: From 12 up to 45 BAR

OIL QUANTITY	
MINIMUM LEVEL	45 litres
USEFUL OIL	70 litres
TOTAL OIL	115 litres
POWER UNIT WEIGHT WITHOUT OIL	122 KG

NOTE:

- DISTRIBUTOR: 15-150 L/1'
- REF TABLE # 9017, TO CHOOSE PUMP AND POWER MOTOR
- OUTLET (*) WITH FLEX-PIPE 1" (M36x2)
- OUTLET (*) WITH FLEX-PIPE 1"1/4 (M45x2)
- AUXILIARY TANK AGAINST POWER UNIT OIL SPILLS: SEE TAB. 9291
- CABINET ARRANGEMENT: SEE CAP.16
- HEAT EXCHANGER ARRANGEMENT (** OPTIONAL)

UT		DATA SHEET POWER UNIT CM320-R-MARK2	DATE	09/22
			DWG Nr.	9018/CM320R-MK2

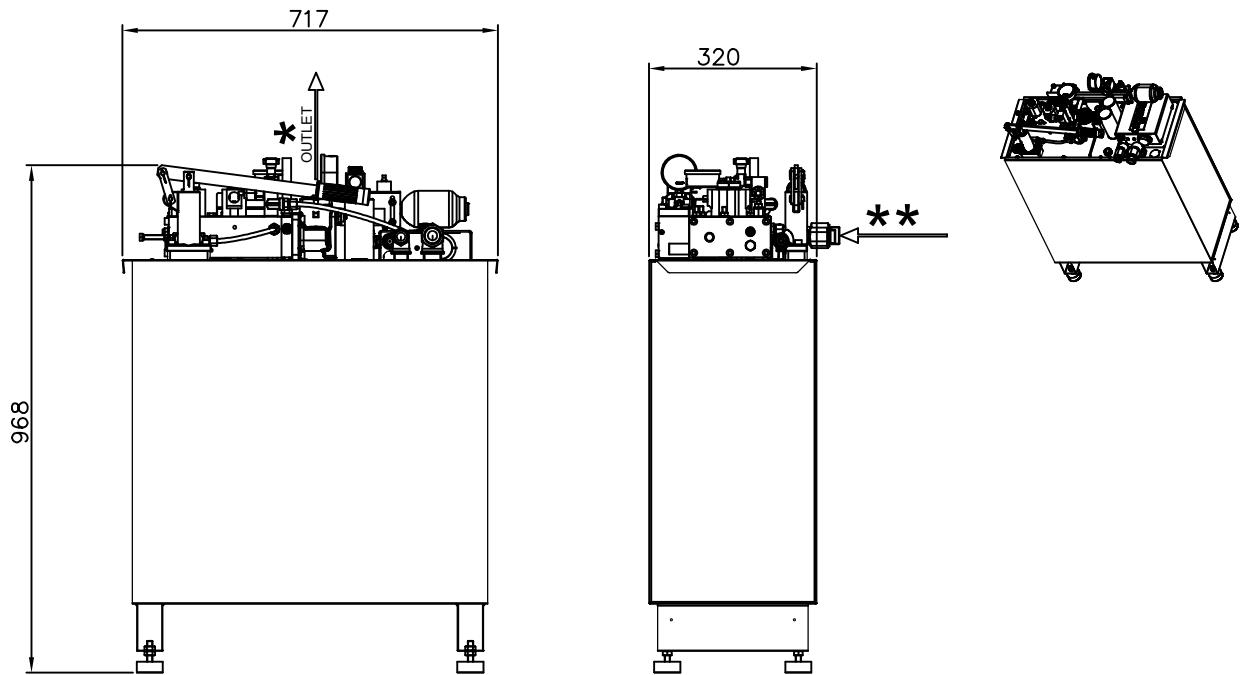

THREE-PHASE MOTOR: From 2.7 up to 13 CV (2 / 9.5 kW)
 230 V-400 V-415 V ; (50/60 HZ)
MONO-PHASE MOTOR: From 2 up to 8 CV (1.5 / 6 kW)
PUMP: From 30 up to 150 L/min.
PRESSURE: From 12 up to 45 BAR

OIL QUANTITY	
MINIMUM LEVEL	45 litres
USEFUL OIL	70 litres
TOTAL OIL	115 litres
POWER UNIT WEIGHT WITHOUT OIL	115 KG

NOTE:

- DISTRIBUTOR: 15-150 L/1'
- REF TABLE # 9017, TO CHOOSE PUMP AND POWER MOTOR
- OUTLET (*) WITH FLEX-PIPE 1"1/4 (M45x2)
- OUTLET (*) WITH FLEX-PIPE 1" (M36x2)
- AUXILIARY TANK AGAINST POWER UNIT OIL SPILLS: SEE TAB. 9291
- CABINET ARRANGEMENT: SEE CAP.16
- HEAT EXCHANGER ARRANGEMENT (** OPTIONAL)

UT		DATA SHEET POWER UNIT CM320-R-MK2-A	DATE 09/22
			DWG Nr. 9018/CM320R-MK2-A

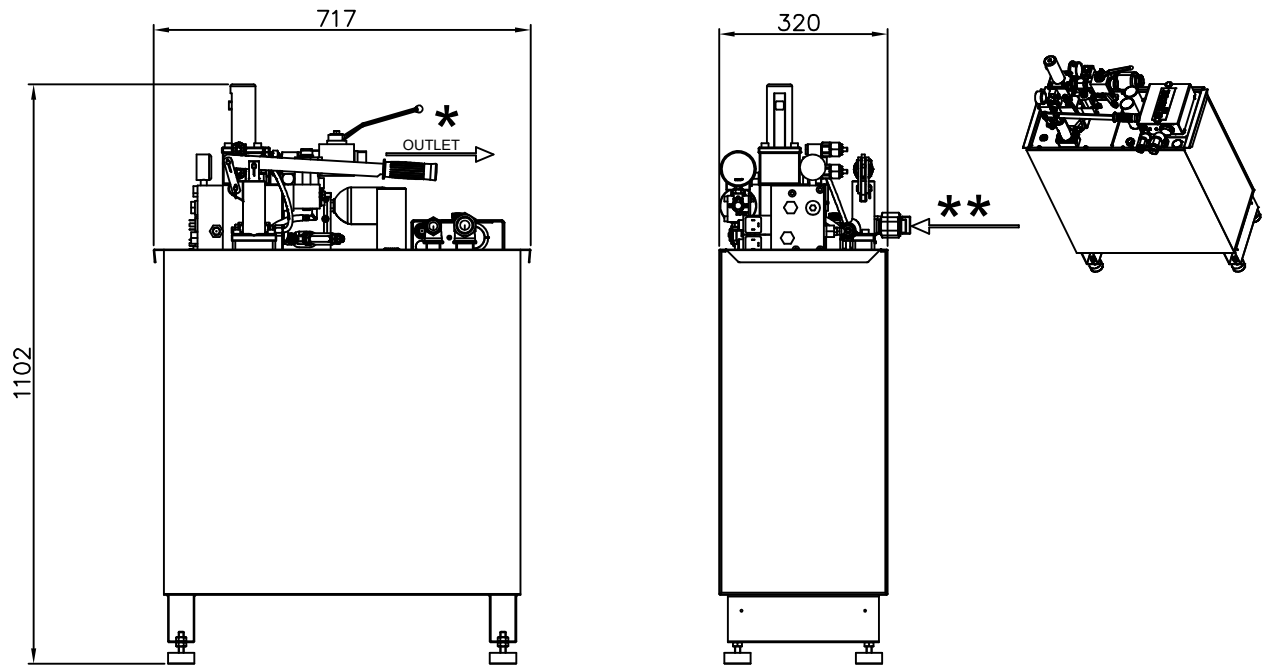

THREE-PHASE MOTOR: From 2.7 up to 13 CV (2 / 9.5 kW)
230 V-400 V-415 V ; (50/60 HZ)

MONO-PHASE MOTOR: From 2 up to 8 CV (1.5 / 6 kW)

PUMP: From 30 up to 150 L/min.

PRESSURE: From 12 up to 60 BAR

OIL QUANTITY	
MINIMUM LEVEL	45 litres
USEFUL OIL	70 litres
TOTAL OIL	115 litres
POWER UNIT WEIGHT WITHOUT OIL	115 KG

NOTE:

- DISTRIBUTOR: LRV-175
- REF TABLE # 9017, TO CHOOSE PUMP AND POWER MOTOR
- OUTLET (*) WITH FLEX-PIPE 1" (M36x2)
- OUTLET (*) WITH FLEX-PIPE 1"1/4 (M45x2)
- AUXILIARY TANK AGAINST POWER UNIT OIL SPILLS: SEE TAB. 9291
- CABINET ARRANGEMENT: SEE CAP.16
- HEAT EXCHANGER ARRANGEMENT (** OPTIONAL)

UT		DATA SHEET POWER UNIT CM320-R-MARK2-LRV	DATE 10/18
			DWG Nr. 9018/CM320RMK2LRV

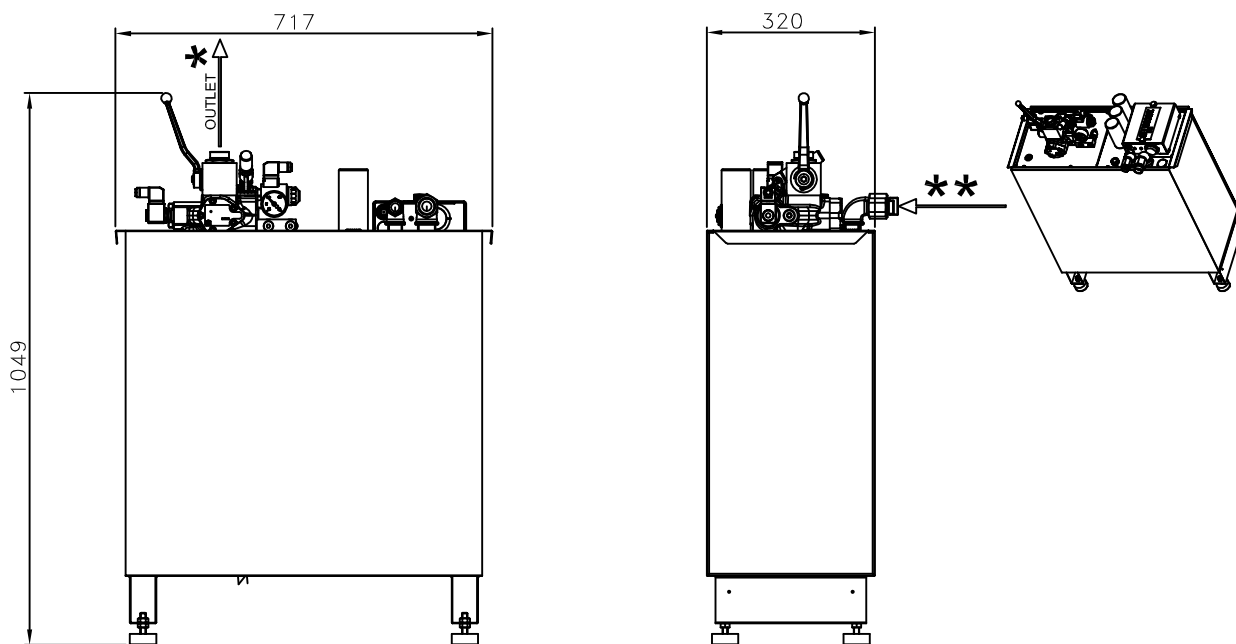

THREE-PHASE MOTOR: From 2.7 up to 13 CV (2 / 9.5 kW)
230 V-400 V-415 V ; (50/60 HZ)

MONO-PHASE MOTOR: From 2 up to 8 CV (1.5 / 6 kW)

PUMP: From 30 up to 150 L/min.

PRESSURE: From 12 up to 60 BAR

OIL QUANTITY	
MINIMUM LEVEL	45 litres
USEFUL OIL	70 litres
TOTAL OIL	115 litres
POWER UNIT WEIGHT WITHOUT OIL	115 KG

NOTE:

- DISTRIBUTOR:I-VALVE 250/160
- REF TABLE # 9017, TO CHOOSE PUMP AND POWER MOTOR
- OUTLET (*) WITH FLEX-PIPE 1" (M36x2)
- OUTLET (*) WITH FLEX-PIPE 1"1/4 (M45x2)
- AUXILIARY TANK AGAINST POWER UNIT OIL SPILLS: SEE TAB. 9291
- CABINET ARRANGEMENT: SEE CAP.16
- HEAT EXCHANGER ARRANGEMENT (** OPTIONAL)

UT		DATA SHEET POWER UNIT CM320-R-MARK2-IV	DATE	10/18
			DWG Nr.	9018/CM320RMK2IV

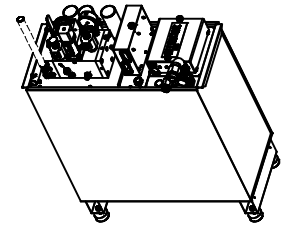
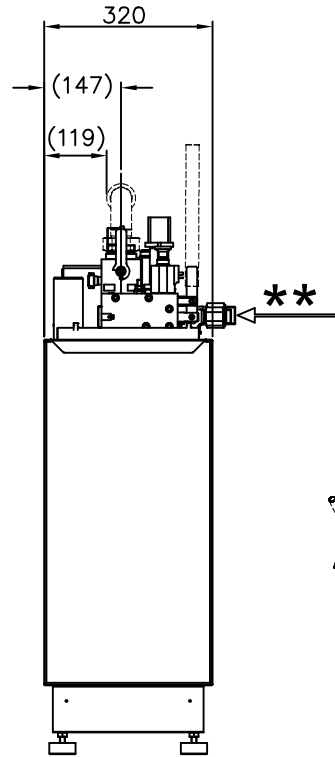
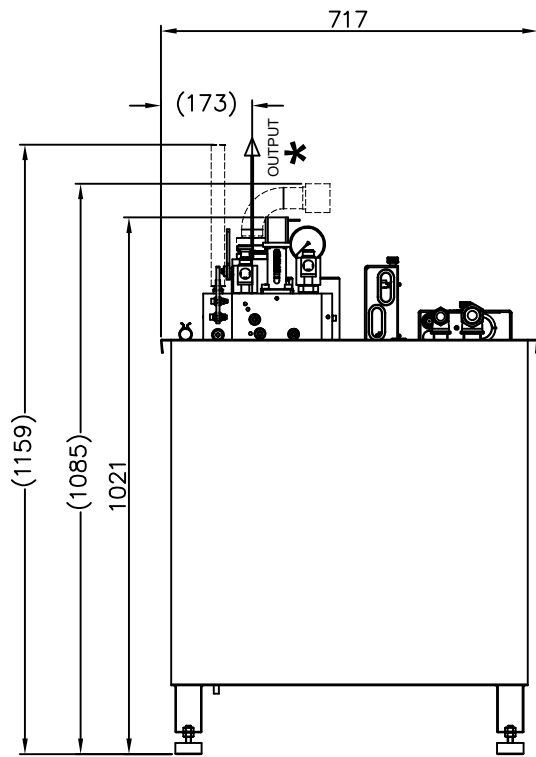

THREE-PHASE MOTOR: From 2.7 up to 13 CV (2 / 9.5 kW)
230 V-400 V-415 V ; (50/60 HZ)

MONO-PHASE MOTOR: From 2 up to 8 CV (1.5 / 6 kW)

PUMP: From 30 up to 150 L/min.

PRESSURE: From 10 up to 50 BAR

OIL QUANTITY	
MINIMUM LEVEL	45 litres
USEFUL OIL	70 litres
TOTAL OIL	115 litres
POWER UNIT WEIGHT WITHOUT OIL	115 KG

NOTE:

- DISTRIBUTOR: VEM 250
- REF TABLE # 9017, TO CHOOSE PUMP AND POWER MOTOR
- OUTLET (*) WITH FLEX-PIPE 1" (M36x2)
- OUTLET (*) WITH FLEX-PIPE 1 1/4" (M45x2)
- AUXILIARY TANK AGAINST POWER UNIT OIL SPILLS: SEE TAB. 9291
- CABINET ARRANGEMENT: SEE CAP.16
- HEAT EXCHANGER ARRANGEMENT (** *) OPTIONAL

UT	

DATA SHEET
POWER UNIT CM320-R-MARK2-VEM

DATE	09/21
DWG Nr.	9018/CM320RMK2VEM