

**THREE-PHASE MOTOR:** From 2.7 up to 20 CV (2 / 15 kW)  
 230 V-400 V-415 V ; (50/60 HZ)  
**MONO-PHASE MOTOR:** From 2 up to 8 CV (1.5 / 6 kW)  
**PUMP:** From 30 up to 150 L/min.  
**PRESSURE:** From 12 up to 45 BAR

OIL QUANTITY	
MINIMUM LEVEL	50 litres
USEFUL OIL	85 litres
TOTAL OIL	135 litres
POWER UNIT WEIGHT WITHOUT OIL	125 KG

**NOTE:**

- DISTRIBUTOR: 15-150 L/1'
- REF TABLE # 9017, TO CHOOSE PUMP AND POWER MOTOR
- OUTLET ( \* ) WITH FLEX-PIPE 1" (M36x2)
- OUTLET ( \* ) WITH FLEX-PIPE 1"1/4 (M45x2)
- AUXILIARY TANK AGAINST POWER UNIT OIL SPILLS: SEE TAB. 9291
- CABINET ARRANGEMENT: SEE CAP.16
- HEAT EXCHANGER ARRANGEMENT ( \*\* OPTIONAL)

UT		<b>DATA SHEET</b> <b>POWER UNIT CM320-MARK2</b>	DATE	09/22
			DWG Nr.	9018/CM320-MK2

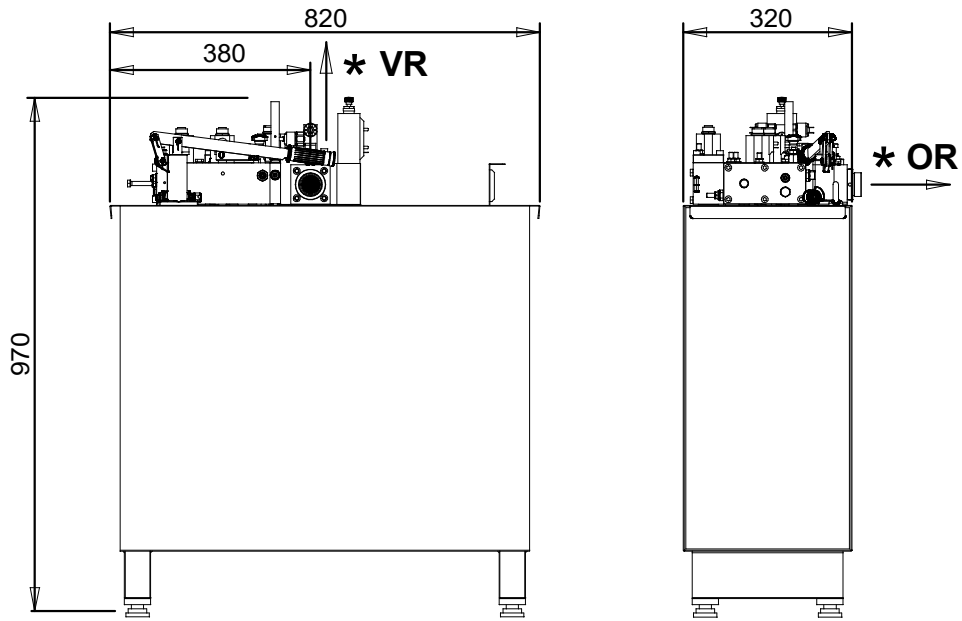

**THREE-PHASE MOTOR:** From 2.7 up to 20 CV (2 / 15 kW)  
230 V - 400 V - 415 V; (50/60 HZ)

**MONO-PHASE MOTOR:** From 2 up to 8 CV (1.5 / 6 kW)  
**WITHOUT FLYWHEEL**

**PUMP:** From 30 up to 150 L/1'

**PRESSURE:** From 12 up to 45 BAR

**SPECIAL EXECUTION:**

- A) PUMP 180 L/1'
- B) FLEX-PIPE 1"1/2 (M52x2)  
FOR PUMP 180 L/1'
- C) HEAT EXCHANGER ARRANGEMENT  
(STANDARD)
- D) CONNECTION KIT EXCHANGER  
(OPTIONAL)

OIL QUANTITY (with engine size and maximum pump)	
MINIMUM LEVEL	40 litres
USEFUL OIL	90 litres
TOTAL OIL	130 litres

EMPTY POWER UNIT WEIGHT	115 KG
-------------------------------	--------

**NOTE:**

- DISTRIBUTOR: 15-150 L/1'
- REF TABLE # 9017 - 9018 TO CHOOSE PUMP AND POWER MOTOR
- OUTLET ( \* ) WITH FLEX-PIPE 1" (M36x2) or 1"1/4 (M45x2)
- CABINET ARRANGEMENT:  
0884/CM3-...

**OR** - HORIZONTAL OUTLET

**VR** - VERTICAL OUTLET

UT	

**TECHNIQUE SHEET**  
**POWER UNIT: CM-320-MARK2-A**

DATE	09/22
DWG N° 9018	
CM-320-MK2-A	

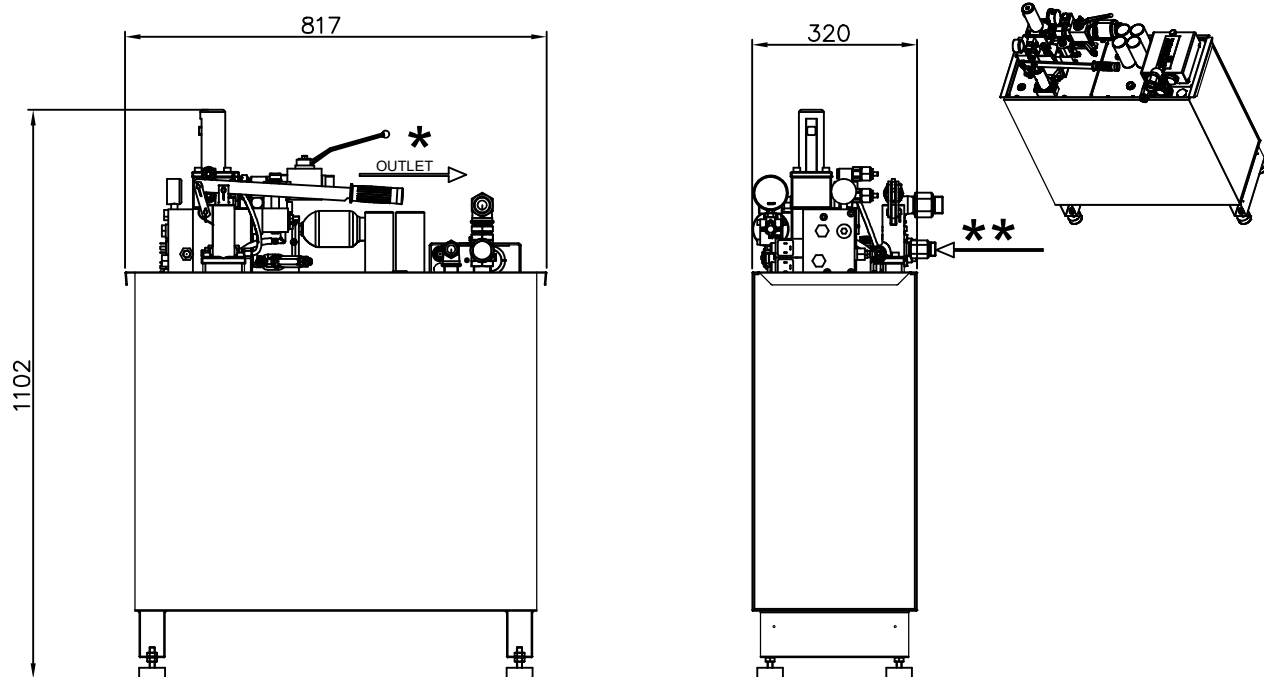

**THREE-PHASE MOTOR:** From 2.7 up to 20 CV (2 / 15 kW)  
230 V-400 V-415 V ; (50/60 HZ)

**MONO-PHASE MOTOR:** From 2 up to 8 CV (1.5 / 6 kW)

**PUMP:** From 30 up to 150 L/min.

**PRESSURE:** From 12 up to 60 BAR

OIL QUANTITY	
MINIMUM LEVEL	50 litres
USEFUL OIL	85 litres
TOTAL OIL	135 litres
POWER UNIT WEIGHT WITHOUT OIL	117 KG

**NOTE:**

- DISTRIBUTOR: LRV-175
- REF TABLE # 9017, TO CHOOSE PUMP AND POWER MOTOR
- OUTLET ( \* ) WITH FLEX-PIPE 1" (M36x2)
- OUTLET ( \* ) WITH FLEX-PIPE 1"1/4 (M45x2)
- AUXILIARY TANK AGAINST POWER UNIT OIL SPILLS: SEE TAB. 9291
- CABINET ARRANGEMENT: SEE CAP.16
- HEAT EXCHANGER ARRANGEMENT ( \*\* OPTIONAL)

UT	<b>DATA SHEET</b> <b>POWER UNIT CM320-MARK2-LRV</b>	DATE 11/18
		DWG Nr. 9018/CM320MK2LRV

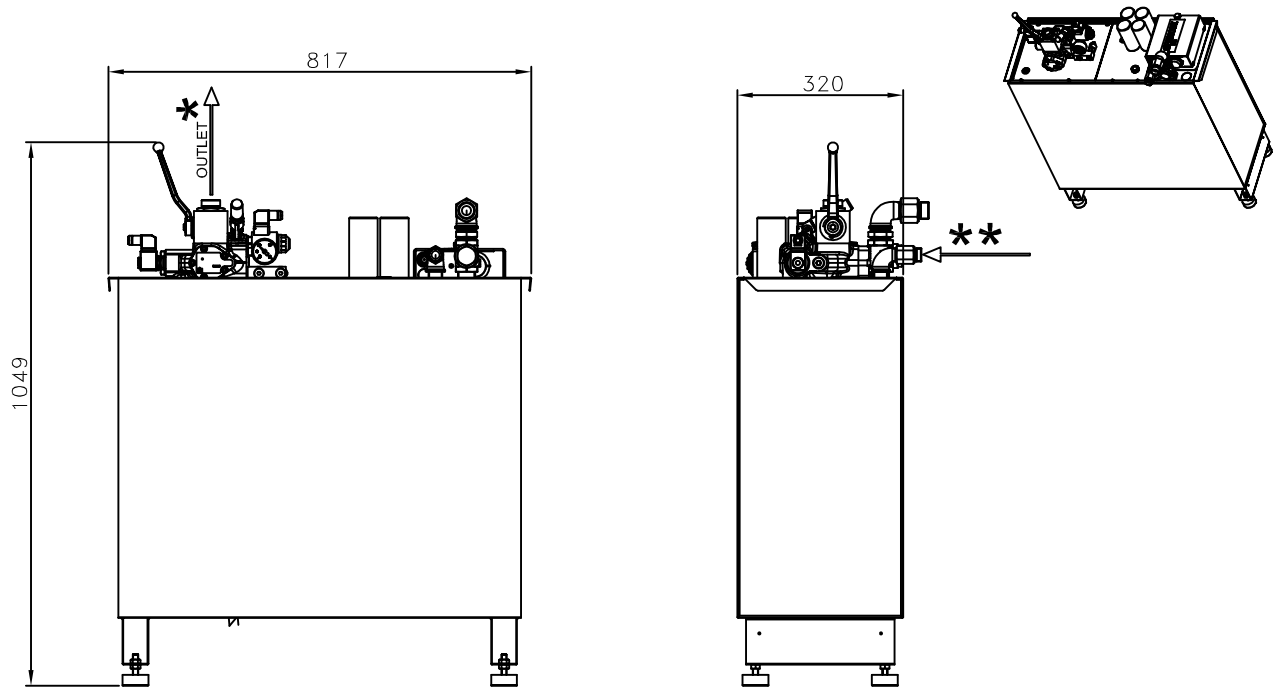

**THREE-PHASE MOTOR:** From 2.7 up to 20 CV (2 / 15 kW)  
 230 V-400 V-415 V ; (50/60 HZ)

**MONO-PHASE MOTOR:** From 2 up to 8 CV (1.5 / 6 kW)

**PUMP:** From 30 up to 150 L/min.

**PRESSURE:** From 12 up to 60 BAR

OIL QUANTITY	
MINIMUM LEVEL	50 litres
USEFUL OIL	85 litres
TOTAL OIL	135 litres
POWER UNIT WEIGHT WITHOUT OIL	117 KG

**NOTE:**

- DISTRIBUTOR: I-VALVE 250/160
- REF TABLE # 9017, TO CHOOSE PUMP AND POWER MOTOR
- OUTLET ( \* ) WITH FLEX-PIPE 1" (M36x2)
- OUTLET ( \* ) WITH FLEX-PIPE 1"1/4 (M45x2)
- AUXILIARY TANK AGAINST POWER UNIT OIL SPILLS: SEE TAB. 9291
- CABINET ARRANGEMENT: SEE CAP.16
- HEAT EXCHANGER ARRANGEMENT ( \*\* OPTIONAL)

UT		<b>DATA SHEET</b> <b>POWER UNIT CM320-MARK2-IV</b>	DATE 10/18
			DWG Nr. 9018/CM320MK2IV

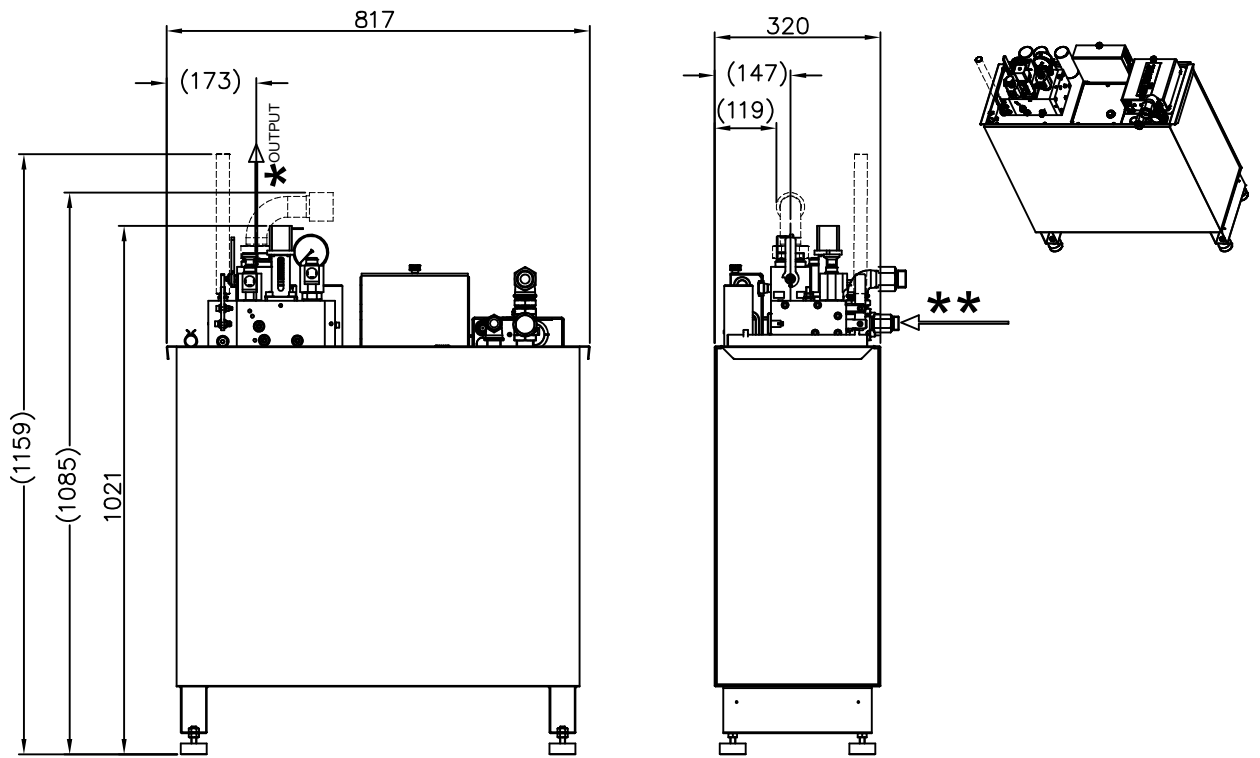

**THREE-PHASE MOTOR:** From 2.7 up to 20 CV (2 / 15 kW)  
 230 V-400 V-415 V ; (50/60 HZ)  
**MONO-PHASE MOTOR:** From 2 up to 8 CV (1.5 / 6 kW)  
**PUMP:** From 30 up to 150 L/min.  
**PRESSURE:** From 10 up to 50 BAR

OIL QUANTITY	
MINIMUM LEVEL	50 litres
USEFUL OIL	85 litres
TOTAL OIL	135 litres
POWER UNIT WEIGHT WITHOUT OIL	117 KG

**NOTE:**

- DISTRIBUTOR: VEM 250
- REF TABLE # 9017, TO CHOOSE PUMP AND POWER MOTOR
- OUTLET ( \* ) WITH FLEX-PIPE 1" (M36x2)
- OUTLET ( \* ) WITH FLEX-PIPE 1"1/4 (M45x2)
- AUXILIARY TANK AGAINST POWER UNIT OIL SPILLS: SEE TAB. 9291
- CABINET ARRANGEMENT: SEE CAP.16
- HEAT EXCHANGER ARRANGEMENT ( \*\* OPTIONAL)

UT	

**DATA SHEET**  
**POWER UNIT CM320-MARK2-VEM**

DATE	09/21
DWG Nr.	9018/CM320MK2VEM

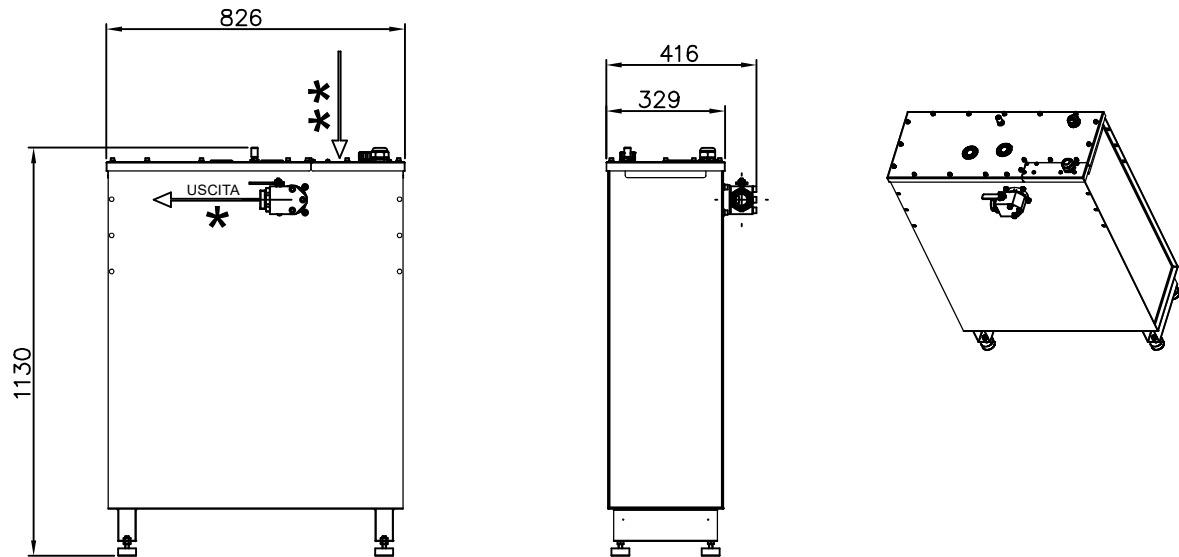

**THREE-PHASE MOTOR:** From 2.7 up to 20 CV (2 / 15 kW)  
 230 V-400 V-415 V ; (50/60 HZ)  
**MONO-PHASE MOTOR:** From 2 up to 8 CV (1.5 / 6 kW)  
**PUMP:** From 30 up to 150 L/min.  
**PRESSURE:** From 12 up to 45 BAR

OIL QUANTITY	
MINIMUM LEVEL	50 litres
USEFUL OIL	85 litres
TOTAL OIL	135 litres
POWER UNIT WEIGHT WITHOUT OIL	135 KG

**NOTE:**

- DISTRIBUTOR: 15-150 L/1'
- REF TABLE # 9017, TO CHOOSE PUMP AND POWER MOTOR
- OUTLET ( \* ) WITH FLEX-PIPE 1" (M36x2)
- OUTLET ( \* ) WITH FLEX-PIPE 1"1/4 (M45x2)
- AUXILIARY TANK AGAINST POWER UNIT OIL SPILLS (CM320MK2): SEE TAB. 9291
- HEAT EXCHANGER ARRANGEMENT ( \*\* OPTIONAL)

UT		DATE
	<b>DATA SHEET</b>	09/22
	<b>POWER UNIT CM320-TS</b>	DWG Nr.
		9018/CM320-TS